



TOWN OF DOVER

MAYOR AND BOARD OF ALDERMEN

CAUCUS MEETING MINUTES July 8, 2008

The Caucus Meeting of the Mayor and Board of Aldermen was held in council chambers, 37 N. Sussex Street, Dover, New Jersey.

Mayor Dodd called the meeting to order at 7:00 pm

All joined in the Pledge of Allegiance to the Flag and prayer was given asking for guidance and strength to do what is right for our town and our citizens.

ROLL CALL:

Present: Aldermen Delaney, Visioli, Donofrio, Picciallo, Romaine and Mayor Dodd

Absent: Aldermen Fahy, Poolas and Timpani

Also present were Attorney Pennella and Clerk Verga

Clerk Verga stated adequate notice was given to the official newspaper.

MUNICIPAL CORRESPONDENCE:

1. Ordinance from the Borough of Wharton Re: Amending chapter XIV Land Use & development
2. Memo from Senator Anthony Bucco's office re: Municipal Aid
3. Letter from OMLAND Engineering Associates, Inc. re: Notice of NJDEP Application/Borough of Wharton, NJ
4. Letter from Dover's Engineering Dept. to the NJ Council on Affordable Housing re: Proposal # PRN 2008-193
5. Notice re: the Borough of Wharton Planning Board's Public Hearing on July 8, 2008
6. Notice re: M.C. Planning, Development & Technology Division of Planning re; Ordinance 17-Amending chapter 236
7. Legal Notice from the M.C. Planning Board-Agricultural Development Board re: Public Hearing on July 17, 2008
8. Letter from Portable on Demand Storage re: an ordinance to regulate the use of portable storage containers
9. Invitation from Splitrock Amateur Radio Assn. to meet with the Amateur Radio operators for National Field Day
10. Legislative Bulletin June 30, 2008, No. 4
11. Letter from M.C. Board of Chosen Freeholders re approval of November's 5K Run
12. Summer 2008 Wind Energy Symposium for NJ Municipality Officials
13. Brochure from Division on Aging, Disabilities & Veteran
14. Letter from Cablevision re: removal of services
15. Newsletter from NJ Dept. of Community Affairs-Council on Affordable Housing
16. Letter from Advanced Business Continuity Solutions, LLC re: management services provided for OPRA
17. Public Hearing Notice from Dept. of Planning, Development & Technology & Copy of plan on a CD ROM

AGENDA ITEMS:

ORDINANCE(S) FOR INTRODUCTION

1. Ordinance # 23-2008 Providing handicapped parking space at 5 Williams Street/Ald. Romaine

ORDINANCE(S) FOR SECOND READING

1. Ordinance #17-2008: Amending Chapter 236, Land Use & Development, Article IV, Zoning/Ald. Romaine
2. Ordinance #18-2008: To Exceed Municipal Budget appropriation Limits & to Establish a Cap Bank/Ald. Picciallo
3. Ordinance #19-2008: Amending & Supplementing Article 28A & Article 38/Ald. Visioli
4. Ordinance #20-2008: Amending & Supplementing Chapter 361: Entitled "Towing"/Ald. Visioli

RESOLUTIONS

1. Approving Bills List
2. Approving submission of a grant application & execute a grant agreement with NJDOT for the Sammis Avenue Roadway Improvements Project
3. Certification of the Annual Audit by the Governing Body
4. Awarding contract for Roadway Improvement for the Small Cities Grant to Jenicar Builders Contractors Co.,

Inc. for 312,715.00

5. Approving Special Permit for Social Event for Global Reach Int. to be held at Baker Theater on Sept. 19, 2008
6. Approving Special Permit for Social Event for Global Reach Int. to be held at Baker Theater on Sept. 20, 2008
7. Approving Municipal License to Operate Amusement Device for Petrin Vending Co.-Unique Bar
8. Approving Renewal of Annual Dance License for Laughing Lion
9. Approving Raffle License for Perfect Pitch HRD, Inc. to be held at Attilio's Tavern
10. Approving Raffle License for Sacred Heart Home & School Association
11. Approving Taxi License for Queen's Limo
12. Approving the issuances of Redemption Certificate for Block 317, Lot 7
13. Approving the Renewal of Alcoholic Beverage License application of Tovar Enterprises, Inc. / Rocky D's Sports Pub.



TOWN OF DOVER

MAYOR AND BOARD OF ALDERMEN

REGULAR MEETING MINUTES
July 8, 2008

The Regular Meeting of the Mayor and Board of Aldermen was held in council chambers, 37 N. Sussex Street, Dover, New Jersey.

The meeting was called to order by Mayor Dodd at 7:34pm

ROLL CALL

Present: Aldermen Fahy (arrived at 7:05), Delaney, Visioli, Donofrio, Picciallo, Romaine and Mayor Dodd
Absent: Aldermen Fahy, Poolas and Timpani

Also present were Attorney Pennella and Clerk Verga

Clerk Verga stated adequate notice was given to the official newspaper.

Mayor Dodd opened this portion of the meeting to the public for agenda items only.

Mayor Dodd's Report – No report; Mayor Dodd has been out of town due to a family illness.

ALDERMEN/COMMITTEE REPORTS –

Alderman Fahy – Absent

Alderman Picciallo –No report until next meeting

Alderman Poolas – Absent

Alderman Donofrio – No report until next meeting

Alderman Timpani – Absent

Alderman Delaney – Alderman Delaney attended and worked the July 4th fireworks. Attended the memorial association meeting

Alderman Visioli – The Personnel Committee has been very active. The town is in receipt of resumes for the administrator's position and the town has posted the position in the League of Municipalities' web site.

Alderwomen Romaine – No report due to illness

Attorney Pennella Report – PBA grievance was heard last week however no decision has been issued.

CONSENT AGENDA

ORDINANCE FOR INTRODUCTION

ORDINANCE NO. 23-2008

AN ORDINANCE OF THE MAYOR AND BOARD OF ALDERMEN OF THE TOWN OF DOVER PROVIDING FOR HANDICAPPED PARKING SPACE AT 5 WILLIAMS STREET

BE IT ORDAINED by the Mayor and Board of Aldermen of the Town of Dover, County of Morris, State of New Jersey, as follows:

SECTION 1. Description for handicap parking space to be located at 5 Williams Street

Said handicap parking space shall be located along the northerly curblineline of Williams Street beginning at a point 136 feet west of the northwesterly curblineline intersection of Spruce Street and Williams Street, thence continuing in a westerly direction for a distance of 20' to a point.

SECTION 2. All ordinances or parts of ordinances inconsistent with this within ordinance are hereby repealed to the extent of such inconsistencies.

SECTION 3. If any section, subsection, sentence, clause, phrase or portion of this ordinance is for any reason held invalid or unconstitutional by any court of competent jurisdiction, such portion shall be deemed a separate, distinct and independent provision, and such holding shall not affect the validity of the remaining portions hereof.

SECTION 4. The Ordinance shall take effect in accordance with law.

Alderman Romaine has moved the foregoing ordinance be adopted and duly seconded by Alderman Picciallo and passed for first reading by the following roll call vote.

Ayes: Aldermen Delaney, Visioli, Donofrio, Picciallo, Romaine and Mayor Dodd
Nays: None Absent: Alderman Fahy, Poolas, Timpani Abstained: None

ORDINANCE(S) FOR SECOND READING

ORDINANCE NO. 17-2008
AN ORDINANCE OF THE MAYOR AND BOARD OF ALDERMAN OF THE TOWN OF DOVER,
COUNTY OF MORRIS AND THE STATE OF NEW JERSEY AMENDING CHAPTER 236, LAND USE AND
DEVELOPMENT, ARTICLE IV, ZONING, OF THE CODE OF THE TOWN OF DOVER.

BE IT ORDAINED by the Mayor and Board of Alderman of the Town of Dover, County of Morris and state of New Jersey as follows:

Section 1

Chapter 236, LAND USE AND DEVELOPMENT, ARTICLE IV, Zoning, is supplemented with the following:

236-38.1 Signage, Awnings and Canopies in the C-1 and C-3 Districts

A. Signage

All signs shall comply with general sign provisions set forth in Section 236-38. A. through L. of the Town's Code except as specifically modified herein. If there is any conflicting standard, the standards set forth herein shall prevail. Nothing herein shall prevent the Historic Preservation Commission from making additional requirements as part of the Certificate of Historic Review process for those properties that lie in the Blackwell Street Historic Preservation District.

(1) General Requirements. Where a building requires several different signs, they shall be thematically linked and shall be similar in materials, color and method of lighting. Internally illuminated signs are not permitted. The maximum gross area of all signs on a given façade shall not exceed 32 square feet.

(2) Wall Signs. Each nonresidential use located on the ground floor and having a street level entrance along a public sidewalk may install wall signage in accordance with all of the following requirements:

(a) The maximum quantity of wall signs for each ground floor business use shall be no more than one (1) wall sign per street frontage.

(b) The sign shall be located on the wall area situated near the main public entrance or centered along the street frontage.

(c) The maximum height from ground-level to uppermost portion of the sign shall not exceed the height of the sill or bottom of any second story window or sixteen (16) feet, whichever is less. In the case of single-story buildings, the maximum height shall not exceed fourteen (14) feet or the top of the wall face, whichever is less.

(d) The minimum height from ground-level to lowermost portion of the sign shall be no less than eight (8) feet.

(e) Maximum permitted sign area shall be no greater than one square-foot per lineal foot of building frontage occupied by the use on that particular building frontage, not to exceed 24 (24) square feet.

(f) Maximum permitted horizontal sign dimension (width) shall be no greater than seventy-five percent (75%) of the width of the building frontage occupied by the use on that particular building frontage, not to exceed eighteen (18) feet.

(g) Maximum vertical dimension (height) of the sign face shall not exceed two (2) feet.

(h) No wall sign shall project more than eight (8) inches from the wall face upon which it is attached.

- (i) The sign shall only be externally or indirectly illuminated.
- (3) Parking Garage Signs. Wall signs identifying an entrance of a parking garage may be permitted but shall be in conformance with regulations set forth above for wall signs.
- (4) Awning Signs. Non-residential uses located on the ground floor may display signs on awnings, provided that the following standards are met:
 - (a) Awning signs shall only be permitted on first-story awnings that provide roof-like shelter and/or solar shielding above doorways and windows.
 - (b) The dimensions of the awning shall be in conformance with applicable regulations set forth elsewhere herein for awnings.
 - (c) The sign shall only be located on the front portion of the awning that is generally parallel to the building wall face to which it is attached. This portion is more commonly known as the “valance” (see Figure 1). In the case of an awning shape where a traditional valance might not be provided, the sign text and graphic characters shall be restricted to the lowest fourteen (14) inches of the awning, which must be shown to be nearly parallel to the building wall face. In the case of dome awnings, the sign graphics shall additionally be restricted to the middle one-fifth (1/5th) of the awning, when viewed from the front elevation, which must be shown to be nearly parallel to the building wall face.
 - (d) All awning signs shall be professionally sewn or painted.
 - (e) The maximum vertical dimension of the sign face (valance) shall not exceed fourteen (14) inches.
 - (f) The maximum height of letters, individual numbers or other characters or images on the awning shall not exceed twelve (12) inches.
 - (g) Maximum width of individual letters, numbers, or other characters or images on the awning shall not exceed eighteen (18) inches.
 - (h) The total aggregate horizontal dimension (width) of all individual letters, numbers or other characters shall not exceed twenty (20) feet, or seventy-five (75%) of the width of the awning, as viewed in front elevation, whichever is less.
 - (i) The awning shall be limited to a total of two (2) colors plus white as approved by the Planning Board, including the color of sign lettering and all other graphics (see Figure 1).
 - (j) No single awning shall contain sign messages for more than two (2) business establishments.
 - (k) The maximum quantity of awning signs for each nonresidential use located on the ground floor shall be no more than two (2) awning signs per street frontage.
 - (l) Awning signs shall not be internally illuminated.

**Figure 1
Awning**

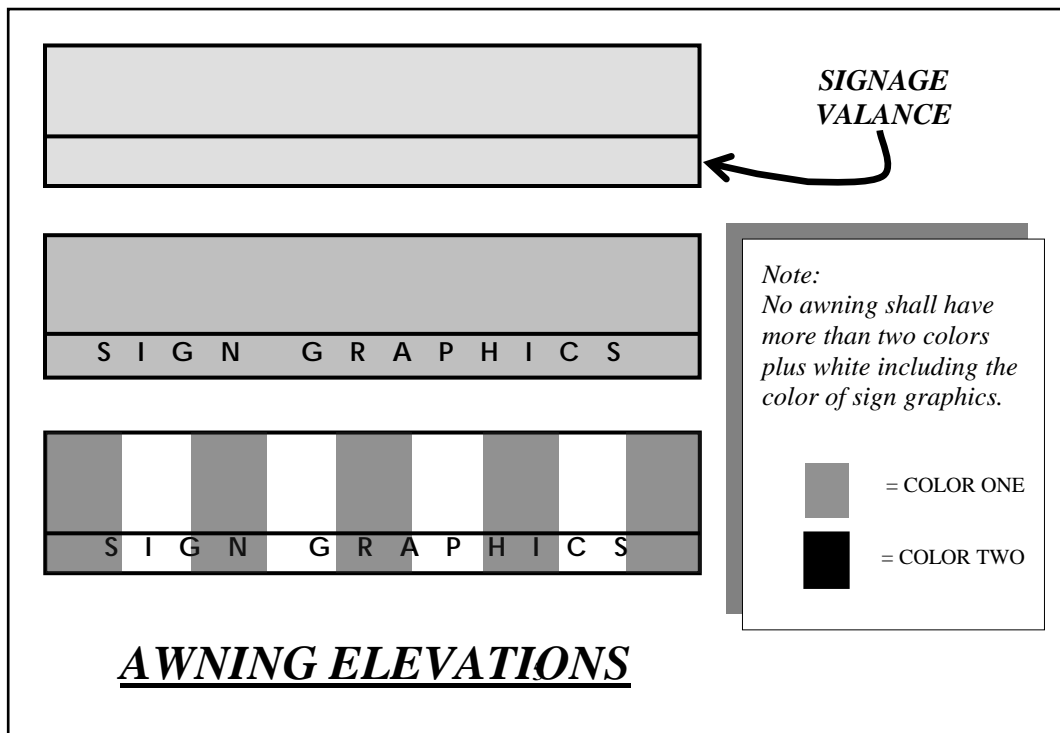

–
Signs

(5) Permanent Window Signs. Only retail or personal service business uses located below the third story of a building shall be permitted to display a permanent window sign. Such sign may be professionally painted on the interior side of a window or may consist of a professionally printed permanent decal(s) installed on the interior side of a window, provided that the following standards are complied with:

- (a) No window sign shall be permitted in a window above the second-story of a building.
- (b) Maximum area of any and all such sign shall not exceed twenty-five percent (25%) of the total window area, not to exceed six (6) square feet in area per window.
- (c) One (1) sign per business establishment per window shall be permitted, up to a maximum of two (2) signs per business on any wall frontage.
- (d) The sign(s) shall be limited to the name and/or type of business, the address and phone number.
- (e) The sign(s) may be internally illuminated.

(6) Wall-mounted Directory Sign. For buildings containing non-residential tenant(s) located above the ground level, one (1) wall-mounted directory sign for each ground floor public entrance into a building shall be permitted whether such entrance fronts on a street or a parking lot.

- (a) The maximum size of the wall-mounted directory sign shall not exceed eight (8) square feet in sign area.
- (b) The maximum height from the ground-level to uppermost portion of the sign shall not exceed nine (9) feet if situated directly above the doorway entrance, or six (6) feet if not situated directly above the doorway entrance.
- (c) The minimum height from ground-level to lowermost portion of the sign shall be no less than two (2) feet.
- (d) Such sign may identify all building occupant names and their addresses, however, no sign message for an individual business shall occupy greater than six (6) square feet in area of such a sign.
- (e) A wall-mounted directory sign may only be externally illuminated with a shielded fixture.
- (f) All lettering on a wall-mounted directory sign shall be of the same type-face (font) style.

(7) Projecting Sign. Each nonresidential use located on the ground floor and having a direct street level entrance may install one (1) projecting sign subject to the following:

- (a) The sign shall be attached to the wall along the frontage such use occupies.
- (b) Such sign face and all signage must be oriented in a position that is perpendicular to the wall to which it is attached.
- (c) No such sign shall have a thickness that exceeds eight (8) inches.
- (d) Maximum size of each sign face shall not exceed six (6) square feet in area.
- (e) Minimum height from ground level to lowermost portion of sign shall be no less than nine (9) feet.
- (f) Maximum height from ground level to uppermost portion of sign shall not exceed the height of the sill or bottom of any second story window or sixteen (16) feet, whichever is less. In the case of single-story buildings, said maximum height shall not exceed fourteen (14) feet or the top of the wall, whichever is less.
- (g) Maximum horizontal projection from the building wall, including any sign appurtenances, shall not exceed three (3) feet. Such sign may project over a public sidewalk only and shall not extend over any other portion of any other public right-of-way.
- (h) Maximum horizontal dimension (width) of the sign face shall not exceed three and one-half (2 ½) feet.
- (i) Maximum vertical dimension (height) of the sign face shall not exceed four (4) feet.
- (j) Maximum height of letters, individual numbers or other characters or images on the signboard shall not exceed twelve (12) inches.
- (k) Maximum width of letters, individual numbers or other characters or images on the signboard shall not exceed twelve (12) inches.
- (l) A projecting sign may be internally or externally illuminated.

- (8) Temporary Window Advertising Signs. Temporary window advertising signs for ground level retail and personal service business uses located in the C-1 and C-3 Districts are exempt from approval requirements, subject to the following conditions:
- (a) Such signs may be constructed of paper, cardboard or plastic, and any written, numerical, graphic or photographic material or information shall constitute such a sign.
 - (b) Such signs shall be removed after a period of thirty (30) days and shall have the date of installation printed clearly in the lower right-hand corner of such, as viewed from the exterior.
 - (c) Such signs shall be contained solely within the ground level window of the subject business.
 - (d) Maximum total area of such signs shall not exceed 40% of the total area of ground level windows, excluding window portions of doors, fronting on a public street. For the purposes of this subsection, any window area covered with a permitted permanent window sign, pursuant to this article, shall be excluded from the calculation of the total area of all ground floor windows.
 - (e) Information on such signs shall be limited to advertisements for special promotions, temporary sales and other such similar nonpermanent sales promotions for the permitted business conducted on the premises on which said sign is located.
 - (f) Such signs shall be maintained in an orderly manner at all times.
 - (g) This section shall not be interpreted in such a manner as to limit or prohibit any business from displaying merchandise in an interior window display area.
- (9) Portable Sidewalk Sign. Only retail and personal service business uses and eating and drinking establishments shall be permitted to display sandwich board signs and other types of portable signs, subject to the following conditions:
- (a) Maximum size of such signboard shall not exceed five (5) square feet in area. If such sign is two-sided, only one (1) side of such shall be used for the purpose of calculating the permitted sign area.
 - (b) Maximum height and width of letters, numbers or other characters or images on the signboard shall not exceed twelve (12) inches.
 - (c) Such signs shall be located within four (4) feet of an entrance to the business they advertise and shall not be placed so as to interfere with pedestrian or vehicular traffic on a street, sidewalk, walkway or public right-of-way. An unobstructed pathway of at least four (4) feet in width must be maintained on a sidewalk at all times.
 - (d) Such signs shall be constructed of wood, slate board and/or finished metal.
 - (e) Information contained on such signs shall be limited to advertisements for special promotions, sales and other such similar non-permanent sales promotions for the permitted business conducted on the premises adjacent to which said sign is located.
 - (f) Such signs shall be maintained in an orderly manner at all times.
 - (g) In a building with multiple business occupants who share a common entrance, no more than two (2) such signs shall be permitted, which may be shared among the applicable businesses entitled to a portable special promotion sign under the provisions of this section.
 - (h) Any business use that places or installs such sign, pursuant to this section, shall be required to conform to all other applicable provisions of this article, otherwise, such business shall be prohibited from displaying such sign.
 - (i) No such sign shall be displayed when the business it relates to is not open for business.
 - (j) Such signs shall not be illuminated.
- (10) Freestanding and Ground Signs. Freestanding and Ground signs are not permitted.
- (11) Residential Use Signage. Signage pertaining to residential uses shall be in accordance with the signage requirements set forth in the Town's Code for residential uses.

B. Awnings and Canopies

Awnings and canopies are encouraged in the C-1 and C-3 Districts at the street level of a building when occupied by a nonresidential use. For all uses, awnings and canopies may be used on the upper floors of a building, where appropriate. The design of awnings and canopies shall be architecturally compatible with the style, materials, colors and details of such

buildings and should not conceal significant architectural features, such as cornices, columns, pilasters or other trim details. Nothing herein shall prevent the Historic Preservation Commission from making additional requirements as part of the Certificate of Historic Review process for those properties that lie in the Blackwell Street Historic Preservation District. All of the following standards for street-level awnings and canopies shall additionally apply:

1. The highest point of a street-level awning or canopy shall not extend above the top of the first-story windows by more than four (4) feet or fourteen (14) feet above the sidewalk grade elevation, whichever is less.
2. The minimum height clearance between the sidewalk and the lowest point of an awning or canopy shall be no less than seven feet six inches (7'-6").
3. The maximum horizontal projection dimension of an awning from the building wall, including any appurtenances, shall not exceed six (6) feet from the building face. Awnings may project over a public sidewalk but shall not be closer than two (2) feet to the vertical plane of the curb line or the edge of any other public right-of-way.
4. No permanent canopy structure with a projection greater than eight (8) inches from the building wall face shall project over a public right-of-way (including a public sidewalk), unless approved by the governing body of the Town.
5. When fully extended and viewed in side elevation, the height dimension of an awning shall not exceed the projection from the wall face (see Figure 2 below).
6. The surfacing material of awnings shall be made of canvas or modern materials that mimic canvas with traditionally dyed colors in solids or stripes. Metal and vinyl awnings are prohibited. Canopies shall be made of materials permitted for awnings or may be made of architectural materials found on the façade of the building.
7. No awning shall contain more than two (2) colors plus white. The color of any sign messages or other graphic features shall be included in the number of colors. The colors must be compatible with the architectural color scheme of the entire building.
8. On buildings with multiple storefronts, coordinating awning and canopy frame styles shall be used as a means of unifying the structure.
9. All signage on awnings shall be in conformance with applicable regulations set forth elsewhere herein for awning signs.
10. All signage mounted, affixed or displayed directly on a fixed-position canopy shall be regulated as wall-mounted signs in accordance with applicable regulations set forth elsewhere herein for wall signs.
11. Internally illuminated or backlit awnings and canopies are not appropriate and are therefore strictly prohibited. No awning or canopy shall have illumination which permits the passage of light or allows light to be seen through the surface material of the awning or canopy so as to illuminate the exterior of the awning or canopy.

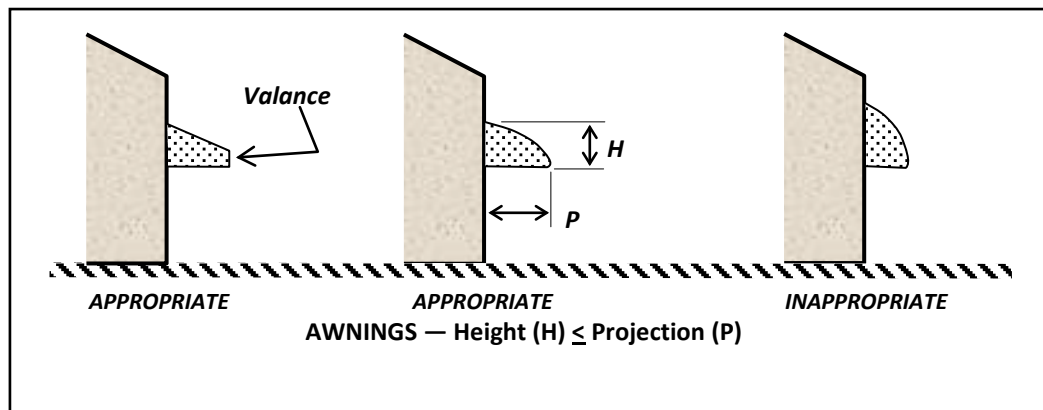

Figure 2 – Awning Proportion

Section 2

All ordinances or parts of ordinances inconsistent with this ordinance are hereby repealed to the extent of such inconsistencies.

Section 3

If any article, section, subsection, paragraph, phrase or sentence is, for any reason, held to be unconstitutional or invalid, said article, section, subsection, paragraph, phrase or sentence shall be deemed severable.

Section 4

This ordinance shall take effect immediately upon final publication as provided by law.

Mayor Dodd opened the meeting to the public for a hearing, seeing no hands and hearing no voices this portion of the meeting was closed.

Alderwoman Romaine has moved the foregoing ordinance be adopted and duly seconded by Alderman Visioli and passed for second reading by the following roll call vote.

**Ayes: Aldermen Delaney, Visioli, Donofrio, Picciallo, Romaine and Mayor Dodd
Nays: None Absent: Alderman Fahy, Poolas, Timpani Abstained: None**

ORDINANCE NO. 18-2008
CALENDAR YEAR 2008 ORDINANCE TO EXCEED THE MUNICIPAL BUDGET
APPROPRIATION LIMITS AND TO ESTABLISH A CAP BANK N.J.S.A. 40a:4-45.14)

WHEREAS, the Local Government Cap Law, N.J.S.40A"4-45.1 et seq., provides that in the preparation of its annual budget, a municipality shall limit any increase in said budget to 2.5% unless authorized by ordinance to increase it to 3.5% over the previous year's final appropriations, subject to certain exceptions; and,

WHEREAS, N.J.S.A. 40A:4-45.15a provides that a municipality may, when authorized by ordinance, appropriate the difference between the amount of its actual final appropriation and the 3.5% percentage rate as an exception to its final appropriations in either of the next two succeeding years; and

WHEREAS, the Mayor and Board of Aldermen of the Town of Dover in the County of Morris finds it advisable and necessary to increase its CY 2008 budget by up to 3.5% over the previous year's final appropriations, in the interest of promoting the health, safety and welfare of the citizens; and,

WHEREAS, the Mayor and Board of Aldermen hereby determines that a 1% increase in the budget for said year, amounting to \$126,50.87 in excess of the increase in final appropriations otherwise permitted by the Local Government Cap Law, is advisable and necessary; and,

WHEREAS, the Mayor and Board of Aldermen hereby determine that any amount authorized hereinabove that is not appropriated as part of the final budget shall be retained as an exception to final appropriation in either of the next two succeeding years.

NOW, THEREFORE, BE IT ORDAINED, by the Mayor and Board of Aldermen of the Town of Dover, in the County of Morris, a majority of the full authorized membership of this governing body affirmatively concurring, that, in the CY 2008 budget year, the final appropriations of the Town of Dover shall, in accordance with this ordinance and N.J.S.A. 40A:4-45.14, be increased by 3.5%, amounting to \$442,764 and that the CY 2008 municipal budget for the Town of Dover be approved and adopted in accordance with this ordinance; and,

BE IT FURTHER ORDAINED, that any amount authorized hereinabove that is not appropriated as part of the final budget shall be retained as an exception to final appropriation in either of the next two succeeding years; and,

BE IT FURTHER ORDAINED, that a certified copy of this ordinance as introduced be filed with the Director of the Division of Local Government Services within 5 days of introduction; and,

BE IT FURTHER ORDAINED, that a certified copy of this ordinance upon adoption, with the recorded vote included thereon, be filed with said Director within 5 days after such adoption.

Mayor Dodd opened the meeting to the public for a hearing, seeing no hands and hearing no voices this portion of the meeting was closed.

Alderman Picciallo has moved the foregoing ordinance be adopted and duly seconded by Alderwoman Romaine and passed for second reading by the following roll call vote.

**Ayes: Aldermen Fahy, Delaney, Visioli, Donofrio, Picciallo, Romaine and Mayor Dodd
Nays: None Absent: Alderman Poolas, Timpani Abstained: None**

ORDINANCE NO. 19-2008
AN ORDINANCE OF THE MAYOR AND BOARD OF ALDERMEN OF THE TOWN OF DOVER
AMENDING AND SUPPLEMENTING ARTICLE 28 A AND ARTICLE 38 OF THE REVISED ORDINANCES
OF THE TOWN OF DOVER, 1969, SAVED FROM REPEAL

BE IT ORDAINED by the Mayor and Board of Aldermen of the Town of Dover, Morris County, New Jersey as follows:

1. Article 38, entitled "Streets, Gutters and Sidewalks," Chapter G, entitled "One-Way Streets" of the Revised Ordinances of the Town of Dover, 1969, Saved from Repeal under the Code of the Town of Dover is amended and supplemented as follows:

A. Boonton Street is hereby established as a one-way street easterly from South Morris Street to South Highland Street.

2. This ordinance shall be submitted to the municipal engineer and he shall, under his seal as a licensed professional engineer, certify to the governing body of the Town of Dover that the action taken above has been approved by him as municipal engineer after investigation of the circumstances, and that it appears to the engineer to be in the interest of safety and expedition of traffic on the public highways and conforms to the current standards prescribed by the manual of the Uniform Traffic Control Devices for Streets and Highways as Adopted by the Commissioner of Transportation, all as required by N.J.S.A. 39:4-8.

3. A certified copy of the adopted ordinance, as certified by the municipal engineer, shall be transmitted by the clerk of the Town of Dover to the Commissioner of Transportation within 30 days of adoption.

4. All ordinances or parts of ordinances inconsistent with this within ordinance are hereby repealed to the extent of such inconsistencies.

5. If any section, subsection, sentence, clause, phrase or portion of this ordinance is for any reason held invalid or unconstitutional by any court of competent jurisdiction, such portion shall be deemed a separate, distinct and independent provision, and such holding shall not affect the validity of the remaining portions hereof.

5. The Ordinance shall take effect in accordance with law.

Mayor Dodd opened the meeting to the public for a hearing, seeing no hands and hearing no voices this portion of the meeting was closed.

Alderman Visioli has moved the foregoing ordinance be adopted and duly seconded by Alderwoman Romaine and passed for second reading by the following roll call vote.

Ayes: Aldermen Fahy, Delaney, Visioli, Donofrio, Picciallo, Romaine and Mayor Dodd
Nays: None Absent: Alderman Poolas, Timpani Abstained: None

ORDINANCE NO. 20-2008
AN ORDINANCE OF THE MAYOR AND BOARD OF ALDERMEN OF THE TOWN OF DOVER
AMENDING AND SUPPLEMENTING CHAPTER 361, ENTITLED "TOWING"

Be it ORDAINED by the Mayor and Board of Aldermen of the Town of Dover as follows:

Chapter 361 of the Code of the Town of Dover is amended and supplemented as follows:

§361-1 Definitions

As used in this chapter, the following terms shall have the meanings indicated:

ADMINISTRATIVE CHARGES — Charges for post-accident services, including but not limited to services such as physical inspection, telephone and/or fax calls, removal of personal items and additional paperwork.

AUTOMOBILE — A motor vehicle of a private passenger or station wagon type that is owned or leased and is neither used as a public or livery conveyance for passengers nor rented to others with a driver, and a motor vehicle with a pickup body, or delivery sedan, a van or panel truck or a camper-type vehicle used for recreational purposes owned by an individual or husband and wife who are resident of the same household, not customarily used in the occupation, profession or business of the owner(s).

BASIC TOWING SERVICE — The removal and transportation of an automobile from a highway, street or other public or private road or a parking area or from a storage facility and other services normally incident thereto, but does not include recovery of an automobile from a position beyond the right-of-way or berm or from being impaled upon any other object within the right-of-way or berm.

CATEGORY I VEHICLE — All vehicles up to 6,000 pounds gross vehicle weight ("GVW").

CATEGORY II VEHICLE — All vehicles 6,000 pounds to 26,000 pounds GVW.

CATEGORY III VEHICLE — All vehicles 26,000 pounds and over GVW.

CLEANUP — Cleanup and/or removal of debris or mechanical work to ready the vehicle for towing. Does not include supplies and labor to clean up an accident scene, absorbent material, and debris.

INSIDE BUILDING — A vehicle storage facility that is completely indoors, having one or more openings in the walls, for storage and removal of vehicles and that is secured by a locking device on each opening.

MOTOR VEHICLE ACCIDENT — An occurrence in which a private passenger automobile comes in contact with any other object for which the private passenger automobile must be towed or removed for placement in a storage facility. This includes all situations which are accidental as to the licensed owner or operator of the motor vehicle even if they were caused by the intentional acts of a perpetrator where the perpetrator was not the licensed owner or operator of the motor vehicle.

OUTSIDE SECURED — An automobile storage facility that is not indoors and is secured by a fence, wall or other man-made barrier that is at least six feet high and is installed with a locked gate. The facility is lighted at night.

RECOVERY — Recovery can be achieved by several actions which may include but are not limited to winching and rigging. A recovery is when the tow operator applies his knowledge in a skillful manner to preserve the condition of the motor vehicle while moving the damaged vehicle to a towable position.

STORAGE CHARGES FOR TWENTY-FOUR-HOUR PERIOD — The maximum allowable amount to be charged by a storage facility for a twenty-four-hour period or fraction thereof; a new twenty-four-hour period begins at 12:01 a.m. of the succeeding day.

TOW VEHICLE — Only those vehicles equipped with a boom or booms, winches, slings, tilt beds, wheel lifts or underreach equipment specifically designed by its manufacturer for the removal or transport of motor vehicles.

TOW VEHICLES BASE OR PLACE OF SERVICE — The towing operator's principal place of business where the tow vehicle is stationed or when not in use.

VEHICLE REMOVAL CHARGE — Charge for a motor vehicle towed into the storage facility of the primary tower that is not movable and must be towed out of the primary tower's storage facility to a public street for towing by the secondary tower.

WAITING TIME — Additional time a tow operator spends at the scene other than the time required for the actual tow and/or recovery. Examples of waiting time may include but are not limited to EMS services which must be performed and/or police investigations.

WINCHING — The process of moving a motor vehicle by the use of the cable from a position that is not accessible for direct hookup by conventional means for loading onto a tow vehicle. Winching is not pulling a vehicle onto a tilt bed or carrier nor lifting a motor vehicle with a conventional tow sling.

§ 361-2. Designation and licensing of official towers.

A. The governing body of the Town of Dover, hereinafter "Town," shall license persons or companies meeting the criteria set forth in this chapter and engaged in the business or offering the services of a motor vehicle towing, wrecker or storage services, whereby damaged or disabled motor vehicles are towed or otherwise removed from the place where they are damaged or disabled by use of a tow vehicle, as defined herein. Such person or company shall be known as an "official tower."

B. Official towers shall be identified by means of a license which shall be issued by the Town as hereinafter provided. Each licensed official tower shall also have issued by the Town a decal or insignia for each vehicle used in the towing operation by the official tower and which shall be placed on each vehicle in a prominent portion of such vehicle as required by the Chief of Police or his designee. No vehicle or motorized equipment shall engage in towing vehicles unless such insignia or decal is affixed as set forth and the name of the official tower permanently affixed to the vehicle. "Permanently affixed" herein shall mean attached to or placed on the vehicle in such a manner as such cannot be removed or repositioned.

C. No person may engage in municipal towing at police request without first obtaining a license therefore as provided by this chapter. Nothing in this chapter shall apply to persons who operate a wrecker or tow truck that picks up disabled vehicles outside the Town limits and are in the course of taking such vehicles to a garage or other location, either within or without the Town, nor to wreckers or tow trucks whose services are specifically requested by the driver or owner of a disabled vehicle.

§ 361-3. Furnishing of service by official towers.

A. The official tower shall furnish adequate and proper towing, wrecking, storage and emergency repair service to

damaged or disabled motor vehicles within the limits of the Town when requested to do so by the Chief of Police or his designee. The official tower shall be available to render service 24 hours per day, seven days per week.

B. In the event that a disabled vehicle requires special towing equipment and the official tower does not possess such equipment, then the Chief of Police or his designee shall select the next official tower in the rotation list who does possess the necessary special equipment to tow such disabled or damaged vehicle. No official tower shall subcontract or assign work to be performed by the official tower under the provisions of this chapter.

§ 361-4. Application for official tower license.

A. Any person, corporation or business firm who desires to perform towing work at police request shall submit an application for a towing license on forms furnished by the Town Clerk to the Chief of Police. The application shall state:

- (1) The full name, address, and telephone number of the applicant. If the application is made for a corporation, it shall state the corporation's registered office, its registered agent, and the names, residences and telephone numbers of all persons owning 10% or more of the shares thereof.
- (2) In the event that the official tower is conducting business under a trade name or business name, the applicant shall submit a certificate of such name filed with the County Clerk's Office of Morris County, as well as the Secretary of State of the State of New Jersey.
- (3) Such information as may be required by the Mayor and Board of Aldermen or designees concerning the personnel, vehicles, equipment, storage facilities of such applicant, as hereinafter provided, showing that the applicant meets the minimum standards of performance.
- (4) Certificates of insurance evidencing adequate insurance coverage as hereinafter provided.
- (5) An annual fee of \$125 to cover the administrative expenses incurred by the Town in processing the applications and an additional fee of \$50 for each vehicle for which an identifying decal is issued.
- (6) All towing vehicles must be listed on the application, including the make and model number, year of vehicle and vehicle identification number. No vehicle may be listed on more than one application.
- (7) The tower shall contact the New Jersey State Police at (609) 882-2000 and request background check forms for each owner, member of the corporation, director, stockholder, partner and employee. The tower, upon receipt of the forms, will have each employee, owner and other person having an ownership interest in the business complete the forms and return the original forms with the required funds for each form and a copy of each form to the Town Police Department. This procedure will be followed by the licensed tower for each new hire. No person found to have a criminal record shall have an ownership interest in a licensed tower's business.

B. No license shall be granted to a tower unless and until he has appointed the Town Clerk as the applicant's true and lawful attorney for the purpose of acknowledging service out of any court of competent jurisdiction to be served against the applicant.

C. Upon receipt of complete application, the Town Clerk shall forward a copy to the Chief of Police or his designee for his review and recommendation. The review by the Chief of Police or his designee shall consist of the following:

1. A background check to determine if either the applicant [all owners as defined in Subsection A(1) above] or the applicant's personnel (all persons authorized or licensed to drive a towing vehicle) have been convicted of a criminal offense or have had their driver's license suspended or revoked within the past year. Conviction of a criminal offense or suspension of a driver's license within the past year shall be a cause for disqualification from inclusion on the official towers list. No person who has been convicted of a criminal offense or whose driver's license has been suspended shall be employed as a driver of a tow truck or wrecker by the official tower. A background check shall be made for any person employed by the official tower after a license has been issued.
2. An inspection of the personnel, vehicles, equipment and storage areas proposed to be utilized by the applicant to verify the accuracy of the information contained in the application and to determine compliance with applicable laws and regulations and the standards of performance required by this chapter.
2. An updated list of personnel with all information required pursuant to Subsection C(1) above provided to the Town Clerk at least 10 calendar days prior to the tower assuming its position as the Town's official tower.

§ 361-5. Investigation.

A. After receiving a letter of application for a towing license, the Chief of Police shall conduct or cause to be conducted an investigation to determine the truth and accuracy of all the information contained in the application, whether the applicant and all employees are fit and proper persons to conduct the proposed business, whether the applicant has demonstrated, by his equipment capacity, the location of the business and the location to which requests will be directed during on-call hours, the ability to respond to calls 24 hours a day and whether such ability to respond is sufficient to provide a response to any location within the Town within 10 minutes of request made by the Police Department of the Town from 6:00 a.m. to 6:00 p.m., and 20 minutes from 6:01 p.m. to 5:59 a.m. The investigation shall be completed within 21 days of receipt of the application from the Town Clerk. Upon completion of his investigation, the Chief of Police shall forward a copy of the letter of application for a towing license to the Town Mayor and Council, along with a recommendation for approval or disapproval of the license and the reasons, if any, for disapproval.

B. Upon receipt of the application, the Mayor and Board of Aldermen shall determine within 14 days, or at its next public meeting, whichever is later, whether or not the applicant has complied with all the necessary standards and criteria, and if it shall so find, the license shall be issued to the applicant, and the applicant's name shall be placed at the end of the towing list. The applicant, or its representative, shall be given notice of the date on which the Mayor and Council shall consider the application and shall be permitted to appear and to be heard at that time. Written notice of the approval or denial of the application shall be provided to the applicant within seven days of the decision of the Mayor and Board of Aldermen.

§361-6. Issuance of license.

A. Upon approval of the application as herein provided, the Town Clerk shall issue for the applicant an official tower's license for each tow vehicle or flatbed vehicle to be utilized in providing services pursuant to this chapter by submitting such to the Chief of Police or his designee for submission to the official tower.

B. Said licenses and identifying decal shall be affixed by the Chief of Police, or his designee at police headquarters, which shall be in the form approved by the Mayor and Board of Aldermen, and shall be displayed on the tow vehicle or flatbed vehicle at all times.

C. Expiration, renewal; revocation.

(1) Each official tower's license shall expire December 31 of every calendar year, and the license shall run for the calendar year only. Each applicant for an official tower's license or renewal shall apply for such license on or before October 1 of any calendar year for the next succeeding calendar year, and the license shall not be transferable or assigned and may be subject to revocation by the Mayor and Board of Aldermen for any of the following reasons:

- (a) If it is subsequently determined that the applicant knowingly and with intent to deceive made false, misleading or fraudulent statements of material fact in the application or in any other document required pursuant to this chapter.
- (b) Violation of any federal or state law or municipal ordinance or regulation relating to the operation of a motor vehicle or the provision of towing services.
- (c) Violation of any rule or regulation promulgated by the New Jersey Department of Insurance.
- (d) Violation of any provisions of this chapter.

(2) No license shall be issued for less than a full calendar year nor should a license be issued at any time other than the period set forth above.

D. Upon the expiration of an official tower's license, the applicant, prior to performing any service thereafter, shall refile completely for such official tower's license, setting forth all the information required in the form provided by the Town Clerk and complying with the provisions of this chapter.

§ 361-7. Insurance.

A. No towing license shall be issued under this chapter until the applicant has provided the Town Clerk with a certificate of insurance which complies with N.J.S.A. 39:3-84.8. This insurance shall remain in effect during the entire term of licensure. On all liability policies, the Town shall be added as an additional insured, and insurance certificates shall indicate such coverage as primary coverage notwithstanding any insurance carried by the Town.

B. The tower shall indemnify the municipality and the public against any loss due to injuries, accidents or damages of any character whatsoever where any such damage is the result of act or omission of the tower, his agents or employees in or due to the execution of the work called for under the contract.

C. Certified copies of all insurance policies provided above or certificates thereof satisfactory to the Town shall be furnished forthwith. Each such policy or certificate shall contain a provision that it is not subject to change, cancellation or non-renewal unless 30 days' prior written notice via certified mail, return receipt requested, shall have been given to the Town by the tower's insurer. These must be received 30 days prior to the commencement of work.

D. The providing of any insurance required herein does not relieve the tower of any of the responsibilities or obligations assumed by the tower for which the tower may be liable by law or otherwise.

E. If any policies contain deductibles or co-payments, it shall be the responsibility of the tower to pay such sums at the same time a claim is settled by the tower's insurance company.

F. If any policies contain limits of liability with an aggregate limit, the tower or the tower's insurance company shall provide the Town, quarterly during the policy period, a statement evidencing the limits of liability required under this chapter to be in force.

G. Failure to provide and continue in force such insurance as required above shall be deemed a major breach of the chapter and shall cause immediate termination thereof.

H. All policies shall be written in either a company licensed to do business in the State of New Jersey or a New Jersey eligible Surplus Lines Company, with a minimum best rating of A-. They shall be written on an ISO (Insurance Service Office) form or better.

§ 361-8. Minimum standards of performance.

To qualify for inclusion on the list of official towers, applicants must meet the following minimum standards:

A. Minimum vehicle requirements.

1. Every official tower shall maintain and have available to render services required by this chapter a minimum of one regular tow vehicle with wheel lift, one flatbed vehicle and at least one medium- or one heavy-duty towing vehicle of at least 26,000 pounds gross weight. Registration documents shall be shown to the Town certifying registration is the same or better than the gross weight vehicle (GWV) of the vehicle as plated on the vehicle.

2. Vehicle classes.

(a) Tow vehicles of 26,000 pounds gross vehicle weight or less must be equipped with a boom or winch assembly mounted on the chassis, a tow sling or tow bar and a wheel lift assembly or under reach. The winch assembly must have 100 feet of at least three-eighths-inch or seven-sixteenths-inch steel cable attached to a motor driven winch.

(b) Flatbed vehicles must be equipped with a winch or hydraulically operated bed which slides or tilts to accommodate the transporting of vehicles.

3. Each applicant shall submit, along with its application, proof of ownership or lease of the vehicles which will be utilized to provide services pursuant to this chapter.

B. Minimum equipment and reporting requirements.

(1) Every tow vehicle or flatbed shall have two-way radio or cellular telephone capability with a dispatching center on a twenty-four-hour basis.

(2) Every tow vehicle or flatbed shall be equipped with the following:

(a) At least one amber rotating beacon or strobe light mounted on the highest practical location of the vehicles, visible from 360° when in use and visible at a minimum distance of 500 feet during daylight hours. An amber light permit, as required by the State of New Jersey, must be filed in the office of the Chief of Police and Town Clerk.

(b) Safety tow lights or magnetic tow lights for towing vehicles at night, amber or red colored.

(c) Extra chains and cables for pulling or securing a towed vehicle.

(d) At least one heavy-duty broom, a shovel, a crowbar or pry bar, a set of jumper cables, a flashlight, one two-pound or larger fire extinguisher of dry chemical type, one dozen flares or similar warning devices for placement at the scene of an accident or behind a disabled vehicle, at least 10 pounds of dry sand or a drying compound for gasoline and oil spilled on the roadway and containers for removal thereof and a sufficient quantity and types of tools to enable the tow vehicle operator to perform proper and adequate emergency repair services for the tow.

(3) Every tow vehicle or flatbed vehicle shall comply with any and all state, federal and local laws, regulations and ordinances pertaining to safety, lighting and towing equipment requirements and shall be subject to inspection by the Chief of Police or his designee at any time. Where applicable, all permits required by other agencies than the Town shall be provided to the Town upon the request of the Town.

(4) Every tow vehicle or flatbed vehicle shall display the official tower's decal and shall have the name of the official tower, by permanently affixed or painted sign, prominently displayed on the outside panels of the vehicle (both sides). The sign shall be at least three inches in height and diameter, visible to the naked eye, and the names must be the same on both panels.

C. Minimum personnel requirements. Official towers shall have available, at all times, a minimum of two drivers to provide the services required by this chapter. All drivers employed by official towers to provide services covered by this chapter shall meet the following requirements and be subject to the following regulations:

- (1) Be competent and able to provide minimum road service for disabled vehicles.
- (2) Have a valid commercial driver's license under the laws of the State of New Jersey.
- (3) Obey all traffic laws and regulations.
- (4) Not have been convicted of a crime within the past year.

D. Minimum storage requirements.

(1) Every official tower shall maintain an inside building and outside secured storage area meeting the following requirements:

(a) All official towers must have sufficient storage area on their own premises to store towed vehicles at the licensed site. This area must be over and above the requirement that is in effect for requirement of parking for that site. No vertical stacking of vehicles is permitted. Each tow vehicle must be stored at the official tower's licensed site. All official towers located within the Town cannot store vehicles on the thoroughfares of the Town, whether under the auspices of the Town, County of Morris or State of New Jersey, without Town approval. Storage of vehicles on the thoroughfares of other municipalities wherein Town towers are located is subject to the requirements of those municipalities.

(b) The location of the storage area shall be either within the limits of the Town or in those municipalities which are contiguous to the Town. In those contiguous municipalities, the site and office must be within two miles from the border of the Town.

(c) The outside storage area shall be fenced with an acceptable screened material six feet in height. The fenced area shall be no less than 3,000 square feet in area. The storage area shall have a suitable gate and be installed with a locking device or similar on site security. The facility is to be lighted at night.

(d) The inside storage area shall be heated, well lighted and clean.

(e) The storage areas shall be available 24 hours per day, 365 days per year and shall be open to the public on weekdays during normal business hours. For weekend access, prior arrangements need to be made between the tower and the customer. The applicant shall prominently display the hours during which the facility will be open on weekends. The storage area must have a building on the premises where the official tower states it is doing business wherein a permanently installed telephone is located which must be in the name of the official tower and listed in at least one telephone book promulgated with telephone numbers for residential and commercial entities within the Town. The building shall be within sight distance and/or within 500 feet of the entrance of the storage area. On the application for a towing license, the applicant shall list all business hours required pursuant to the subsection for the calendar year of the license in question, which shall not be changed within that calendar year.

(f)The official tower shall have an employee on duty during all hours in which the storage facility is open. While the official tower is serving on his rotation week and as the first backup, the official tower shall be available for vehicle pickup 24 hours a day; at other times, the tower shall be available for pickup of vehicles between 8:00 a.m. and 5:00 p.m. unless other arrangements are made.

(g)The official tower shall not charge any additional fee or other charge for releasing vehicles to their owners after normal business hours or on weekends or for moving a vehicle from one location to another in the storage area.

(2)The applicant shall, with its application, submit proof of ownership or lease of the storage area.

(3)The official tower shall be responsible for ensuring the proper and safe storage of all vehicles towed pursuant to this chapter. The official tower shall be liable for any damage incurred by such vehicles while in transit to or while stored in the storage areas.

§ 361-9. Order of list of official towers; rotation.

A. Official towers shall be placed on the list in the order in which their application is approved and license issued. Once the initial list has been established, new official towers, when their applications have been approved, will be added at the end of that list. Tow list shall consist of at least three towers. This list is at the discretion of the Chief of Police or his designee.

B. The Town shall request wrecking, towing and storage services from each official tower in rotation. When called, the tower shall advise the dispatcher if a vehicle is available and the estimated time of arrival. If no tow vehicle is available, or the estimated time of arrival will exceed 20 minutes, the next official tower on the list shall be called. If none of the official towers are available or able to provide services as are requested by the Town, the Town may request such services from any other available source. All requests shall be made by the Chief of Police or his designee.

C. The Town shall request service only from official towers; provided, however, that if no emergency or road hazard exists, the Chief of Police or his designee shall request such service from such other person as the owner of the motor vehicle in need of such services may request, provided that service is responded to within 20 minutes.

D. During adverse weather conditions, heavy traffic conditions or emergency conditions, official towers shall give priority to requests from the Town over any other requests which may be received by the official

§ 361-10. Towing and storage fee schedule.

A. Fees for the towing and storage of private passenger vehicles damaged in an accident or recovered after being stolen may not exceed the fees established by the Department of Insurance, if any. In the event the fees are enacted and/or revised by the Commissioner of Insurance, the enacted or revised fees shall be the maximum fees that may be charged by the official towers, and this chapter shall be amended annually. All charges are per vehicle unless otherwise indicated.

1. The following rates are applicable within the purpose and intent of this chapter:

(a)Towing charge.

[1] Category I (all vehicles up to 6,000 pounds GVW): \$95 per vehicle.

[2] Category II (all vehicles 6,001 pounds to 26,000 pounds GVW): \$135 per vehicle.

[3] Category III (all vehicles 26,001 pounds and over GVW): \$285 per hour per vehicle.

(b)Administrative charge: \$35 per vehicle.

(c)Cleanup and/or labor charge: \$40 per hour plus materials, to be charged in thirty-minute increments with a one-hour minimum.

(d)Heavy-duty under reach (Categories II and III vehicles only): \$250 per hour, to be charged in thirty-minute increments with a one-hour minimum.

(e)Jump starts: \$45 per vehicle.

(f)Lockouts: \$45 per vehicle.

(g)Recovery.

[1] Category I (above): \$150 per hour, to be charged in thirty-minute increments with a one-hour minimum.

[2] Category II (above): \$250 per hour, to be charged in thirty-minute increments with a one-

hour minimum.

[3] Category III (above): \$350 per hour, to be charged in thirty-minute increments with a one-hour minimum.

(h)Storage inside building.

[1] Category I (above): \$45 per day.

[2] Category II (above): \$60 per day.

[3] Category III (above): \$90 per day.

(i)Outside secured storage.

[1] Category I (above): \$35 per day.

[2] Category II (above): \$50 per day.

[3] Category III (above): \$85 per day.

(j)Tire changes: \$55 per vehicle.

(k)Vehicle removal: \$35 per vehicle.

(l)Waiting time: \$50 per hour, to be charged in thirty-minute increments with a one-hour minimum.

(m)Winching cable (to be used only when the vehicle has left the roadway): \$95 per hour, to be charged in thirty-minute increments with a one-hour minimum.

(n)Fuel Surcharge shall be ten (10%) percent of the tow.

(o)Collision Wrap/Tarping shall be twenty-five (\$25.00) dollars.

B. The towing operator must only charge the rates set forth in this contract and in conformity with these provisions. No other charges or fees are permitted.

C. The towing operator must not exceed those rates regulated by the New Jersey State Department of Insurance set forth in N.J.A.C. 11:3-38.1 et seq.

D. The towing operator must provide a current and complete rate schedule to all customers and must conspicuously display the rate schedule at all storage facilities.

E. The towing operator must tow the motor vehicle from the location of the police request to the towing operator's storage facilities. This shall constitute a single tow rate.

F. The towing operator is expressly prohibited from charging the owner of the vehicle for towing the vehicle from the original storage facility to another storage facility affiliated with the towing operator.

G. The towing operator is prohibited from charging a release fee for releasing vehicles after normal business hours.

H. The towing operator must accept Visa and MasterCard credit cards and major auto club membership cards 24 hours a day, every date of the year.

I. The towing operator must not charge the owner any additional fees for pulling the vehicle onto the flatbed truck. Winching fees are only permitted to pull the vehicle back onto the roadway and put the vehicle in proper position to hook the vehicle to the tow truck.

J. Mileage fees are not permitted. Additionally, no other fees or charges are permitted except as set forth above. In the event of an extraordinary circumstance which would invoke undue hardship to the towing operator, the Town Police Department must be notified at 973-366-0302 to obtain written approval before the imposition of any assessment. Out of town mileage is \$4.00 per mile one way.

§ 361-11. Prohibited activities.

A. No towing operator shall engage in cruising as defined in this chapter.

B. No towing operator shall solicit or attempt to divert patrons of another towing operator whether or not licensed under this section, nor shall a towing operator solicit or divert prospective patrons of a given repair service to any other repair service, nor shall any police office designate or suggest any towing operator to perform service.

§ 361-12. Miscellaneous provisions.

A. The enforcement committee shall be formed upon final passage of this chapter and shall be appointed by the Mayor, and shall serve at the pleasure of the Mayor, which shall be known as the "Towing Committee." The Towing Committee shall enforce the provisions of this chapter, subject to appeal to the Mayor and Town Council.

B. The enforcement agency shall have the authority to hear complaints against any official tower, whether brought by Town representatives, the public and/or other official towers.

C. The enforcement agency shall have the power to issue subpoenas to compel attendance at the hearing.

D. In the event that a complaint is received by the Town, through either the Town Police Department (of a non-criminal nature) or the Town Clerk or the Committee, involving the improper or unsatisfactory performance of services by an official tower, excessive charges or damage to a motor vehicle while in the custody of the tower, the Committee shall give written notice of said complaint, by certified mail, return receipt requested, to the official tower against whom the complaint is made. Said notice will be mailed within 72 hours of the receipt of the complaint, not counting legal holidays. The official tower shall make a written response to such complaint within five calendar days from receipt of the written notice.

E. The Committee, after hearing the matter, shall make a determination as to whether or not the complaint was justified. If the complaint was justified, the Committee shall have the authority to suspend the official tower's license until the next rotation. Further disposition of such complaint, by appeal of the Committee's action, shall be to the Mayor and Board of Aldermen, which shall conduct a hearing regarding the complaint at the next public Council meeting or within 14 days of the enforcement agency's findings, whichever is later.

F. If violations have been issued against an official tower and heard in municipal court or Superior Court, the Committee may take actions to impose sanctions against an official tower if found guilty by a court, including revocation of the license.

G. If, after considering the matter and the findings by the Committee, the Mayor and Board of Aldermen shall determine that there is good and sufficient cause for revocation of the official tower's license, the tower shall surrender said license to the Town Clerk within one calendar day.

H. Failure to surrender the license upon revocation shall constitute a violation of this chapter, subject to all legal action available to the Town, including permanent removal from the official towers list.

I. Action.

(1) In addition to the foregoing procedures, in the event that the tower fails to comply with any major terms or conditions of this chapter, or charges fees in excess of those set forth in this chapter, the Committee shall have the authority to take the following actions:

(a) First offense: issue a letter of warning detailing the violation of the agreement.

(b) Second offense: suspend the tower's operations under the chapter for 96 hours and utilize alternate towers during this period.

(c) Third and subsequent offenses: suspend the tower's operations under the chapter for 120 hours and use alternate towers during this period.

(d) For any offense involving lack of insurance or a public safety violation the Board may immediately suspend a towing license until further hearing.

(2) For the benefit of both the tower and the Town, it is desirable to provide remedies short of suspension or cancellation of the tower's services. Therefore, violations of the following provisions shall be deemed minor violations: identification of vehicles or employees, equipment or facilities, personnel, conduct, availability and response time, and site cleanup. Minor violations shall be handled on an informal, verbal basis; however, three minor violations of a similar nature will be treated as a major violation and shall trigger a written letter of warning and, if necessary, the subsequent sanctions for a major violation.

J. Nothing contained herein shall prevent or limit the right of any person to commence or maintain an action for damages or any other relief directly against an official tower in a court of competent jurisdiction.

§ 361-13. Violations and penalties.

A. In addition to any suspension or revocation of license, a person who shall violate any of the provisions of this chapter shall be subject to a fine of not less than \$100 and not to exceed \$2,000. Each violation of any of the provisions of this chapter and each day the same is violated shall be deemed and taken to be a separate and distinct offense.

B. In addition to the fine provided above, a violation of any of the provisions of this chapter shall be cause for revocation of the official tower's license.

1. All ordinances or parts of ordinances inconsistent with this within ordinance are hereby repealed to the extent of such inconsistencies.
2. If any section, subsection, sentence, clause, phrase or portion of this ordinance is for any reason held invalid or unconstitutional by any court of competent jurisdiction, such portion shall be deemed a separate, distinct and independent provision, and such holding shall not affect the validity of the remaining portions hereof.
3. The Ordinance shall take effect in accordance with law

Mayor Dodd opened the meeting to the public for a hearing, seeing no hands and hearing no voices this portion of the meeting was closed.

Alderman Visioli has moved the foregoing ordinance be adopted and duly seconded by Alderman Picciallo and passed for second reading by the following roll call vote.

Ayes: Aldermen Fahy, Delaney, Visioli, Donofrio, Picciallo, Romaine and Mayor Dodd
Nays: None Absent: Alderman Poolas, Timpani Abstained: None

RESOLUTIONS

BILLS LIST

WHEREAS, the Mayor and Board of Aldermen of the Town of Dover have examined all bills presented for payment; and

WHEREAS, the Chief Financial Officer has certified that there are sufficient funds in the account(s) to which respective bills have been charged.

NOW, THEREFORE, BE IT RESOLVED that the Mayor and Board of Aldermen of the Town of Dover do hereby approve the bills as listed; and

BE IT FURTHER RESOLVED that the proper officials are hereby authorized to sign the checks for payment of same.

RESERVE ACCT claims in the amount of:	\$1,825.57
CURRENT ACCT claims in the amount of:	\$466,680.32
CAPITAL ACCT claims in the amount of:	\$20,698.68
WATER UTILITY ACCT claims in the amount of:	
WATER UTILITY RESERVE ACCT claims in the amount of:	
WATER CAPITAL ACCT claims in the amount of:	
PARKING UTILITY ACCT claims in the amount of:	\$127,181.16
PARKING UTILITY RESERVE ACCT claims in the amount of:	
PARKING CAPITAL ACCT claims in the amount of:	
ANIMAL CONTROL TRUST ACCT claims in the amount of:	\$3,750.00
EVIDENCE TRUST ACCT claims in the amount of:	
RECYCLING TRUST ACCT claims in the amount of:	\$561.00
COUNTY FORFEITED ASSETS TRUST ACCT claims in the amount of:	\$126.00

FEDERAL FORFEITED ASSETS ACCT claims in the amount of:	
TRUST/OTHER ACCT claims in the amount of:	\$125,233.77
DOVER MARKETPLACE INC TRUST ACCT claims in the amount of:	
TOTAL CLAIMS TO BE PAID	\$746,056.50

BE IT FURTHER RESOLVED that the following claims have been paid prior to the Bill List Resolution in the following amounts:

CURRENT ACCT claims in the amount of:	\$276,044.91
WATER UTILITY ACCT claims in the amount of:	\$21,733.57
PARKING UTILITY ACCT claims in the amount of:	\$2,969.36
PAYROLL AGENCY ACCT claims in the amount of:	\$137,281.23
UNEMPLOYMENT TRUST ACCT claims in the amount of:	\$93.67
TOTAL CLAIMS PAID	\$438,122.74

TOTAL BILL LIST RESOLUTION **\$1,184,179.24**

Alderman Visioli has moved the foregoing resolution be adopted and duly seconded by Alderman Picciallo and passed by the following roll call vote.

Ayes: Aldermen Fahy, Delaney, Visioli, Donofrio, Picciallo, Romaine and Mayor Dodd
Nays: None **Absent: Alderman Poolas, Timpani** **Abstained: None**

RESOLUTION FOR THE NJ DOT GRANT

See Attached

RESOLUTION OF THE GOVERNING BODY CERTIFICATION OF THE ANNUAL AUDIT

WHEREAS, N.J.S.A. 40A:5-4 requires the governing body of every local unit to have an annual audit of its books, accounts and financial transactions, and

WHEREAS, The Annual Report of Audit for the year 2007 has been filed by a Registered Municipal Accountant with the Municipal Clerk as per the requirements of N.J.S.A. 40A:5-6, and a copy has been received by each member of the governing body; and

WHEREAS, R.S. 52:27BB-34 authorizes the Local Finance Board of the State of New Jersey to prescribe reports pertaining to the local fiscal affairs; and

WHEREAS, the Local Finance Board has promulgated N.J.A.C. 5:30-6.5, a regulation requiring that the governing body of each municipality shall, by resolution certify to the Local Finance Board of the State of New Jersey that all members of the governing body have reviewed, as a minimum, the sections of the Annual Audit entitled "Comments and Recommendations; and

WHEREAS, the members of the governing body have personally reviewed, as a minimum the Annual Report of Audit and specifically the sections of the Annual Audit entitled "Comments and Recommendations" as evidenced by the group affidavit form of the governing body attached hereto; and

WHEREAS, such resolution of certification shall be adopted by the Governing Body no later than forty-five days after the receipt of the annual audit, pursuant to N.J.A.C. 5:30-6.5; and

WHEREAS, all members of the governing body have received and have familiarized themselves with, at least, the minimum requirements of the Local Finance Board of the State of New Jersey, as stated aforesaid and have subscribed to the affidavit, as provided by the Local Finance Board; and

WHEREAS, Failure to comply with the promulgations of the Local Finance Board of the State of New Jersey may subject the members of the local governing body to the penalty provisions of R.S. 52:27BB -52- to wit:

R.S. 52:27BB-52: A local officer or member of a local governing body who, after a date fixed for compliance, fails or refuses to obey an order of the director (Director of Local Government Services), under the provisions of this Article, shall be guilty of a misdemeanor and, upon conviction, may be fined not more than one thousand dollars (\$1,000.00) or imprisoned for not more than one year, or both, in addition shall forfeit his office.”

NOW, THEREFORE BE IT RESOLVED, That the Mayor and Board of Aldermen of the Town of Dover, hereby states that it has complied with N.J.A.C.5:30-5.5 and does hereby submit a certified copy of this resolution and the required affidavit to said Board to show evidence of said compliance.

Alderwoman Romaine has moved the foregoing resolution be adopted and duly seconded by Alderman Picciallo and passed by the following roll call vote.

Ayes: Aldermen Fahy, Delaney, Visioli, Donofrio, Picciallo, Romaine and Mayor Dodd
Nays: None **Absent: Alderman Poolas, Timpani** **Abstained: None**

RESOLUTION AWARDING CONTRACT TO JENICAR

See Attached

RESOLUTION

WHEREAS, Global Reach International, filed an application for their **seventh** Special Permit for Social Affair to be held at the Baker Theater, which is their **ninth** event; and

WHEREAS, Global Reach International, a non-profit organization is permitted to have twelve events per year and Baker Theater, is permitted to have twenty-five; and

WHEREAS, the Police Chief will determine what special conditions if any are needed.

NOW, THEREFORE, BE IT RESOLVED by the Mayor and Board of Aldermen of the Town of Dover, County of Morris and State of New Jersey that the following applications for Alcoholic Beverage Social Affair Permit(s) be approved:

1. Global Reach International is approved for a dance (#7) to be held on Friday, September 19, 2008 at Baker Theater, 41 W. Blackwell Street, Dover, NJ (#9) from 6:00 pm through 2:00 am.
2. This approval is conditioned upon security satisfactory to the Town of Dover Chief of Police being in place for this event.

Alderwoman Romaine has moved the foregoing resolution be adopted and duly seconded by Alderman Visioli and passed by the following roll call vote.

Ayes: Aldermen Fahy, Delaney, Picciallo, Romaine and Mayor Dodd
Nays: Aldermen Visioli, Donofrio **Absent: Alderman Poolas, Timpani** **Abstained: None**

RESOLUTION

WHEREAS, Global Reach International, filed an application for their **eighth** Special Permit for Social Affair to be held at the Baker Theater, which is their **tenth** event; and

WHEREAS, Global Reach International, a non-profit organization is permitted to have twelve events per year and Baker Theater, is permitted to have twenty-five; and

WHEREAS, the Police Chief will determine what special conditions if any are needed.

NOW, THEREFORE, BE IT RESOLVED by the Mayor and Board of Aldermen of the Town of Dover, County of Morris and State of New Jersey that the following applications for Alcoholic Beverage Social Affair Permit(s) be approved:

3. Global Reach International is approved for a dance (#8) to be held on Saturday, September 20, 2008 at Baker Theater, 41 W. Blackwell Street, Dover, NJ (#10) from 6:00 pm through 2:00 am.
4. This approval is conditioned upon security satisfactory to the Town of Dover Chief of Police being in place for this event.

Alderman Romaine has moved the foregoing resolution be adopted and duly seconded by Alderman Visioli and passed by the following roll call vote.

Ayes: Aldermen Fahy, Delaney, Picciallo, Romaine and Mayor Dodd
Nays: Aldermen Visioli, Donofrio **Absent: Alderman Poolas, Timpani** **Abstained: None**

RESOLUTION OF THE MAYOR AND BOARD OF ALDERMEN OF THE TOWN OF DOVER APPROVING AMUSEMENT DEVICE LICENSE(S)

WHEREAS, applications for amusement device licenses have been made by the people listed on Schedule A attached hereto and made a part hereof; and

WHEREAS, the appropriate fees have been paid and the license shall be prominently displayed by attaching the same on each device, and

WHEREAS, the placement of each and every amusement game within an establishment must have the approval of the chief of police of the Town of Dover.

WHEREAS, no amusement device shall be installed within two (200) hundred feet of any school or church.

NOW, THEREFORE, BE IT RESOLVED by the Mayor and Board of Aldermen of the Town of Dover, County of Morris and State of New Jersey that the coin operated amusement device licenses for those people listed on Schedule A attached hereto and made a part hereof are hereby approved.

SCHEDULE A

1. Petrin Vending for Unique Bar-97 E. Blackwell Street

Alderman Visioli has moved the foregoing resolution be adopted and duly seconded by Alderman Romaine and passed by the following roll call vote.

Ayes: Aldermen Fahy, Delaney, Visioli, Donofrio, Picciallo, Romaine and Mayor Dodd
Nays: None **Absent: Alderman Poolas, Timpani** **Abstained: None**

RESOLUTION OF THE MAYOR AND BOARD OF ALDERMEN OF THE TOWN OF DOVER APPROVING RENEWAL OF ANNUAL DANCE LICENSE(S)

WHEREAS, Laughing Lion located at 42 No. Sussex Street, Dover, NJ has applied for renewal of their Annual Dance License(s) for the period July 1, 2008 - June 30, 2009; and

WHEREAS, all the applicant(s) have submitted appropriate licensing fee; and,

WHEREAS, the appropriate municipal departments have reviewed the renewal request and have no objections thereto; and

NOW, THEREFORE, BE IT RESOLVED by the Mayor and Board of Aldermen of the Town of Dover, County of Morris and State of New Jersey as follows:

1. An annual dance license is hereby granted for the period July 1, 2008 – June 30, 2009 to the following establishments:

- A. Laughing Lion-42 No. Sussex Street, Dover, NJ

Alderman Visioli has moved the foregoing resolution be adopted and duly seconded by Alderman Romaine and passed by the following roll call vote.

Ayes: Aldermen Fahy, Delaney, Visioli, Donofrio, Picciallo, Romaine and Mayor Dodd
Nays: None **Absent: Alderman Poolas, Timpani** **Abstained: None**

RESOLUTION OF THE MAYOR AND BOARD OF ALDERMEN OF THE TOWN OF DOVER APPROVING OF RAFFLE LICENSE

WHEREAS, the below listed organization has applied for a Raffle License; and

WHEREAS, such license has been reviewed by the appropriate departments and found to meet with all of the requirements and conditions of the municipality;

NOW, THEREFORE, BE IT RESOLVED by the Mayor and Board of Aldermen of the Town of Dover, County of Morris and State of New Jersey as follows:

1. The below listed raffle for the date set forth following their name is hereby approved:

Perfect Pitch HRD Inc. to be held at Attilio's Tavern on December 31, 2008 at 11:30 pm
(Raffle)

Alderman Visioli has moved the foregoing resolution be adopted and duly seconded by Alderman Delaney and passed by the following roll call vote.

Ayes: Aldermen Fahy, Delaney, Visioli, Donofrio, Romaine and Mayor Dodd
Nays: None **Absent: Alderman Poolas, Timpani** **Abstained: Alderman Picciallo**

RESOLUTION OF THE MAYOR AND BOARD OF ALDERMEN OF THE TOWN OF DOVER APPROVING OF RAFFLE LICENSE

WHEREAS, the below listed organization has applied for a Raffle License; and

WHEREAS, such license has been reviewed by the appropriate departments and found to meet with all of the requirements and conditions of the municipality;

NOW, THEREFORE, BE IT RESOLVED by the Mayor and Board of Aldermen of the Town of Dover, County of Morris and State of New Jersey as follows:

1. The below listed raffle for the date set forth following their name is hereby approved:

Sacred Heart Home & School Association - to be held at Fr. Connolly Parish Center on August 1, 2008 at 6-11 pm
(Raffle)

Alderwoman Romaine has moved the foregoing resolution be adopted and duly seconded by Alderman Picciallo and passed by the following roll call vote.

Ayes: Aldermen Fahy, Delaney, Donofrio, Picciallo, Romaine and Mayor Dodd
Nays: None **Absent: Alderman Poolas, Timpani** **Abstained: Alderman Visioli**

RESOLUTION

WHEREAS, At the Town Tax Sale held on November 17, 2004, a lien was sold by former Tax Collector, Ana Hopler, and

WHEREAS, This lien was sold on property owned by Gladys & Harry F. Orchard, also known as Block 317, Lot 7, located at 34-36 Princeton Avenue, and

WHEREAS, This lien know as Tax Title Lien No. 04-001 was sold to Wachovia-Cust/Sass Muni V for fifteen percent (15%) redemption fee, and

WHEREAS, This lien was redeemed by Jose Reyes, with all monies paid to the Town of Dover, and

WHEREAS, Wachovia was paid in full on TTL No. 04-001as authorized by Resolution of the Governing Body on June 27, 2006

WHEREAS, Delivery of the cancelled certificate was never received, and considered lost,

NOW, THEREFORE, BE IT RESOLVED by the Mayor and Board of Alderman, Town of Dover, County of Morris, State of New Jersey that the current Tax Collector issue a Redemption Certificate, to enable those interested parties to cancel of record this lien As paid on the Morris County records.

BE IT FURTHER RESOLVED that two certified copies of this resolution are returned to the Tax Collector.

Alderman Visioli has moved the foregoing resolution be adopted and duly seconded by Alderman Picciallo and passed by the following roll call vote.

Ayes: Aldermen Fahy, Delaney, Visioli, Donofrio, Picciallo, Romaine and Mayor Dodd
Nays: None Absent: Alderman Poolas, Timpani Abstained: None

RESOLUTION

WHEREAS, the herein named duly filed applications for renewal of their Alcoholic Beverage Licenses for their respective premises as shown on Schedule A for July 1, 2008 to June 30, 2009 and

WHEREAS, no objections have been received from the public; and

WHEREAS, the required fees have been paid and all premises have been inspected and approved by the Police Department, Board of Health and the Bureau of Fire Prevention.

NOW, THEREFORE, BE IT RESOLVED by the Mayor and Board of Aldermen of the Town of Dover that said applications be approved and that the respective license(s) be granted; and

BE IT FURTHER RESOLVED that the Town Clerk or Director in the case of a conflict license be and hereby is authorized to issue license certificates accordingly as per attached Schedule A.

Tovar Enterprises Inc.	Rocky D's Sports Pub	1409-33-019-006
	82 King Street	
	Dover, NJ 07801	

Alderman Visioli has moved the foregoing resolution be adopted and duly seconded by Alderman Picciallo and passed by the following roll call vote.

Ayes: Aldermen Fahy, Delaney, Visioli, Donofrio, Picciallo, Romaine and Mayor Dodd
Nays: None Absent: Alderman Poolas, Timpani Abstained: None

PUBLIC COMMENTS – Three Minutes per Person

Andras Szentmiklosy - 84 Maple Avenue – Mr. Szentmiklosy commented on the new parking ordinance for Maple Avenue and explained how difficult it is to find parking and the problems it has caused between neighbors. He also noted the new ordinance brings danger to the street and it's not effective.

Connie Sibona Foster – 90 Penn Ave. – Ms. Foster has noticed that on Dickerson Street and So. Morris Street there are dangerous areas when the flea market is in process for pedestrians. She has noticed loitering around the Zufall Health Center where people are sitting in the middle of the sidewalk which prohibits others from walking on the sidewalk safely.

Carolyn Blackman – 27 Brook Drive – Ms. Blackman asked for the ruling on swimming pools that are bought at stores like Wal Mart and blown up by the owners. She also noted that Elena Street is a one way street however it's difficult to drive through that street when another car is present. She requested to change the street to one-side parking.

Joe Szabo - 305 E. McFarlan Street – He mentioned that E. McFarlan Street was made into a one way street. There’s a portion on the street that is vacated and no one uses for parking. The one-way street is a safety concern when fire trucks, ambulances or children are walking through E. McFarlan.

Debra Mantini – 305 E. McFarlan Street – Ms. Mantini expressed her safety concerns about E. McFarlan Street and how no one utilizes the parking spots.

Antonio Acosta – 130 Madison Street – Mr. Acosta made the board and public aware about the rehabilitation that has occurred in Atlantic City and the changes at their city’s train station. However, he continues to be disgusted with NJ Transit and the way they’ve treated their Dover property. He visited JK Steakhouse in the downtown area however he’s embarrassed with what occurs in the surrounding areas of the JK Steakhouse’s building. He asked if the town has started to crack down on business owners.

**Motion made by Alderwoman Romaine to adjourn at 7:40 p.m.,
Seconded by Alderman Picciallo and passed by the following voice vote.**

Ayes: Aldermen Fahy, Delaney, Visioli, Donofrio, Picciallo, and Mayor Dodd

Nays: None

Absent: Alderman Poolas, Timpani

Abstained: None

Respectfully submitted,

**Margaret J. Verga
Municipal Clerk**